

ACOUSTIC WALL LINER

Series: TAV-500-11A



- Completely isolates the metallic structure.
- Essential for removing noise pollution.
- Isolates fixing screws which eliminates sound leakage.
- Best used with acoustic strip accessory.
- Complies with Spanish building standard UNE 100-153-88.
- Optimal load: 8kg to 30kg per mount.
- Suited for lower U-channels and vertical studs.

MATERIAL

- Polymer Body: Kraiburg TPE
- Metal structure: Steel DX515D + Z272 NA C.

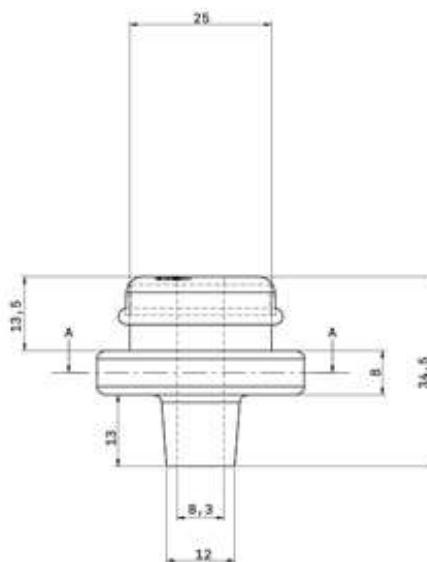
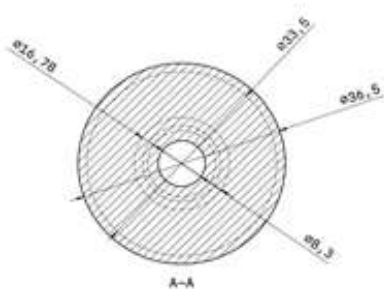

Fire test reports to standards 1364-1:2015 and 13501-2 available upon request.

- [ACOUSTIC SHEET](#)
- [ACOUSTIC TEST REPORT](#)
- [TPE PROPERTIES](#)
- Break Point: 250kg

- Attaches vertical perimeter of the wall lining system/stud wall as well as the lower track.

